

**City College of New York
And
Graduate Center of City University of New York
G5501 Introduction to ROBOTICS**

Homework #2

Due: Sep. 20, 2005

Given the Stanford arm as following figure, where $d_2=0.1$

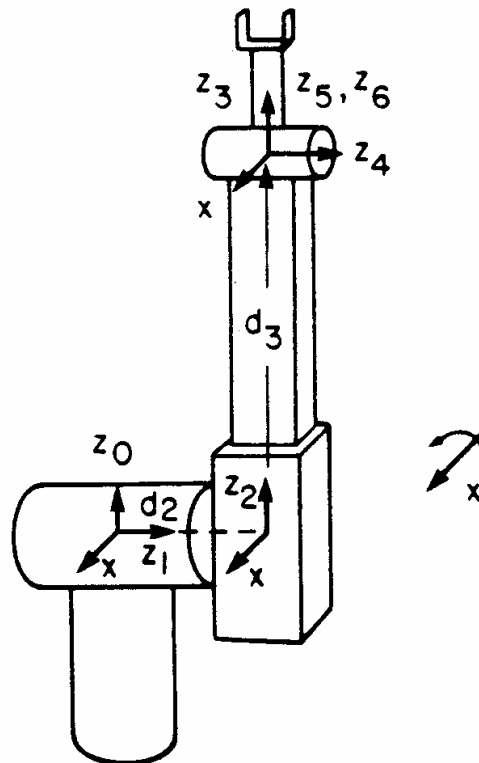

Problem 1: Find the link parameters for the arm. (Note: d_3 is a prismatic joint variable, other joints are rotational joints; the link coordinate frames have been established as shown in the Fig.) (30 points)

Problem 2: Find the forward kinematic model for the arm and represent it in homogeneous matrix form. (Suggestion: the matrix chain product can be done either by hand or using Matlab symbolic toolbox if you have the software, simplify the results) (40 points)

Problem 3: Represent the orientation with Yaw-Pitch-Roll angles. (30 points)